

# **Waxlectric I + II**

**Nr. 2156 / 2157**

**Bedienungsanleitung  
Instruction Manual • Mode d'emploi  
Istruzioni d'uso • Instrucciones de servicio  
Инструкция по эксплуатации  
取扱説明書 • 사용설명서**



Renfert GmbH  
Industriegebiet • 78247 Hilzingen / Germany  
Tel. +49 7731 8208-0 • Fax +49 7731 8208-70  
info@renfert.com • www.renfert.com  
Made in Germany

**Renfert**

0808 21-6544 A

# Waxlectric I + II

No. 2156 / 2157

ENGLISH

## 1. Introduction

We are pleased with your decision to purchase the *Waxlectric I* or *Waxlectric II*. This device sets a new standard with regard to functionality, performance, and safety.



**Please read the following operating instructions carefully and observe the information they contain in order to ensure a long and trouble-free service life.**

- An external transformer supplies the wax knife with 12 V power. As a user, this increases your safety during your daily work with the *Waxlectric*.
- Using a programme key you can save up to 3 temperatures for each channel and quickly call them up again
- The defining feature of the *Waxlectric* is its heater which is located directly in the modelling tips. This allows the tips to react more rapidly to temperature changes. The knife's thermal dynamics are markedly improved by the highly heat conductive special alloy.
- The electric wax knife is extremely service friendly. The modelling tip surfaces are not finished and can therefore be easily reground as required. Should the heater develop a fault, only the tip need be replaced.



**The wax knife (no. 2155-0112, Large Wax Knife (refer to "Accessories")) may not be reground or re-sharpened.**

## 2. Application Area

The *Waxlectric* is an electronically controlled wax knife, suitable for practically all modelling and waxing-up applications.

It is available in either a one- or a two-channel version. The operating temperature can be adjusted in 1°C-increments from 50°C to 200°C [in 2°F-increments from 122°F to 392°F]. However, do not set the temperature

too high, as some waxes are very sensitive to overheating.

### 2.1 Ambient Conditions in Accordance with DIN EN 61010

The unit may only be operated:

- Indoors;
- Up to an altitude of 2,000 m above sea level;
- At an ambient temperature range between 5 - 40°C [41 - 104°F]
- At a maximum relative humidity of 80% at 31°C [87.8°F], dropping in a linear manner to 50% relative humidity at 40°C [104°F]\*);
- With mains power where the voltage fluctuations do not exceed 10% of the nominal value;
- Under over-voltage category II conditions;
- Under contamination level 2 conditions.

\*) Between 5 - 30°C [41 - 86°F], the unit can be operated at a relative humidity of up to 80%. At temperatures between 31 - 40°C [87.8 - 104°F], the humidity must decrease proportionally in order to ensure operational readiness (e.g., at 35°C [95°F] = 65% humidity; at 40°C [104°F] = 50% humidity). The unit may not be operated at temperatures above 40°C [104°F].

## 3. Hazard Information

### 3.1 Symbology



**Danger**

This indicates a direct risk of injury.



**Electrical current**

This indicates a hazard due to electrical current.



**Attention**

**Hot surfaces.**



**Attention**

**Failure to observe the associated information can result in damage to the unit.**

**i** **Note**  
*This provides the operator with useful information to make working with the unit easier.*



Only intended for indoor use.



Observe the operating instructions.

### 3.2 Hazard Information

- The modelling tips can reach a maximum operating temperature of 200°C [392°F].
- While working the tip of the heating handle becomes hot.
- Incorrect handling presents the risk of burns!
- When setting up and operating please pay attention that the cables do not encounter hot parts.
- Always insert the handpiece with the tip into the holder provided on the control unit in order to avoid a potential fire hazard.
- NEVER place the handpiece on a flammable surface or cover it! Fire hazard!
- Do not put any combustible or flammable objects close to the unit.
- The wax knife is solely intended for working modelling waxes.
- NEVER hold the wax knife directly in an open flame (e.g., a Bunsen burner)!
- Processing other materials may result in hazards to the user!
- Only operate the equipment under supervision!
- Only intended for indoor use. The unit is only designed for dry applications and may not be operated or stored outdoors or under wet conditions.
- Units exhibiting damaged connecting lines or other defects must be taken out of service immediately.
- Do not cover the transformer during operation.
- Protect the transformer against water and moisture. Unroll the transformer's

connecting cord during operation (a rolled cord represents an overheating hazard in case of short circuits).

- Use only the OEM mains power supply unit!

### 3.3 Liability Exclusion

Renfert GmbH shall be absolved from all claims for damages or warranty if:

- The product is employed for any purposes other than those cited in the operating instructions;
- The product is altered in any way other than those alterations described in the operating instructions;
- The product is repaired by other than an authorized facility or if any but Renfert OEM parts are employed;
- The product continues to be employed, despite obvious safety faults or damage;
- The product is subjected to mechanical impacts or is dropped.

## 4. Installation / Commissioning

- Screw the desired modelling tip into the handpiece (Figure 1).
- Connect the handpieces to the control unit (Figure 2). The connecting sockets are located on the underside of the control unit. On the 2-channel-models, make sure the handpieces are connected to the correct sockets. The handpieces are marked with coloured rings (red /yellow). The ring colours can also be found on the control unit's operating side (Figure 3).



**The pins must audibly snap into the sockets.**

- Guide the handpiece connecting lines forward through the guide channel or along the side through the openings (Figure 4a, b).
- Connect the transformer to the control unit (Figure 5a). The connecting socket is located on the underside of the control unit.
- Guide the cable out through the opening on the back of the unit (Figure 5b).

- Using the power cord provided, connect the transformer to the mains power supply (Figure 6).

**!** Use only the OEM mains power supply unit!

## 5. Operation

### 5.1 Operating Elements (Figure 7)

A On-off switch

Left channel

B Saved temperature display

C 3-digit temperature display

D Temperature adjustment

E Programme key (P key)

Right channel (Waxlectric II only)

F Saved temperature display

G 3- digit temperature display

H Temperature adjustment

I Programme key (P key)

### 5.2 Switching the Unit ON / OFF

The control unit is switched on and off at switch (A).

After the unit is switched on, the selected unit of temperature measurement ( $^{\circ}\text{C}$  /  $^{\circ}\text{F}$ ) appears on the display for approx. 5 seconds. The current temperature setting is then displayed.

### 5.3 Changing the Unit of Temperature Measurement ( $^{\circ}\text{C}$ / $^{\circ}\text{F}$ )

- Switch the unit off.
- Press the **+** and **-** keys of the left channel and keep them pressed.
- Press the on-off switch and keep it pressed.
  - The currently selected unit of measurement is displayed. After approx. 5 sec., the unit of measurement changes.
- Release all three keys, as soon as the wished temperature unit is displayed.

The unit saves your selection.

**i** **Please note:**  
Units equipped with a power cord terminating in a Euro-plug (in accordance with DIN VDE 0620) are factory pre-set to  $^{\circ}\text{C}$ .

**Units equipped with a power cord terminating in a 2-contact, US flat plug (NEMA 1-15P) are factory pre-set to  $^{\circ}\text{F}$ .**

### 5.4 Temperature Adjustment

The modelling tip temperature is set by means of the two keys on the temperature adjustment.

**+** key: Increases the temperature

**-** key: Decreases the temperature.

The most recently set temperature is saved and will be redisplayed when the unit is again switched on.

New temperatures are saved approx. 5 seconds after they are set.

After a temperature adjustment, the modelling tip requires several seconds to reach the new temperature setting.

**!** **NEVER attempt to heat the tips more rapidly by holding them in an open flame. This will destroy the tips.**

The employed heating elements have been specially tailored to the individual modelling tips.

**i** **However, manufacturing tolerances may result in minor differences between the set temperature and the actual temperature at the modelling tip.**

### 5.5 Calling Up Saved Temperatures

The unit can have up to 3 temperatures saved for each channel.

The selected saved temperature is indicated by a lighted dot on the temperature display.

- Select the desired saved temperature:
  - Briefly press the P key.
  - This calls up the next saved temperature.
  - The saved temperature is displayed and set.
- Factory settings
 

P1:	70 $^{\circ}\text{C}$ [158 $^{\circ}\text{F}$ ]
P2:	120 $^{\circ}\text{C}$ [248 $^{\circ}\text{F}$ ]
P3:	170 $^{\circ}\text{C}$ [338 $^{\circ}\text{F}$ ]

## 5.6 Saving a Temperature

- Saving values:
  - Select a memory location (refer to Sec. 5.5).
  - Using the +/- key, set the desired temperature.
  - Press and hold the P key for at least 2 seconds until the temperature display begins to flash.
  - Your set temperature has now been successfully saved.

## 5.7 Switching channels on and off

You can switch off the heat supply to channels that are not needed.

To do this, press the key  corresponding to the channel until „□ F F“ appears in the display.

To switch a channel that has been switched off back on, press the key  until „□ F F“ is replaced in the display by the temperature setting. Both the temperature setting and the channel that has been switched off are saved. This channel remains switched off when the control unit is switched on again.

 **Also a switched-off channel can be saved as described in chapter 5.6.**

## 5.8 Quick Adjustment of the Final Temperatures

Using this option, you can set the temperature of both channels directly to either the maximum or minimum temperature when the unit is switched on.

Setting the minimum temperature:

- Switch the unit off.
- Press  key of the left channel and keep it pressed.
- Press the on-off switch and keep it pressed.
  - Once the unit of temperature is displayed (°C or °F), both channels are set to 50°C (122°F).

Setting the maximum temperature:

- Switch the unit off.
- Press  key of the left channel and keep it pressed.

- Press the on-off switch and keep it pressed.
  - Once the unit of temperature is displayed (°C or °F), both channels are set to 200°C (392°F).

 **Any channels which are switched off (refer to Sec. 5.7) remain off and are not set to the minimum or maximum temperature.**

## 5.9 Storing the Modelling Tips and Handpieces

You can safely leave unused modelling tips in the tip holder (Figure 8).

During breaks, you can safely leave unused handpieces in the quiver (Figure 9).

 **NEVER insert the handpieces into the tip holder (Figure 10). This can damage both the tip holder as well as the control unit.**

 **NEVER place the handpiece on a flammable surface or cover it! Fire hazard!**

### Tips and Notes

- *In order to reduce the risk of breaking the probes, dip them into the hard wax block with the rounded back section! The wax will melt more quickly and this allows to pick up a greater amount of wax (Figure 18).*
- *More rapid and efficient modellation (time savings of up to 30%!) can be achieved by pre-warming the wax in a Renfert Vario E. Wax can be processed more gently and cools more rapidly. This reduces shrinkage to a minimum.*
- *Because the tip insert surfaces are not finished, they can – starting from their basic shape – be ground, bent, or polished to suit your particular requirements.*

- *The handpiece cables can be guided through an appropriate retainer (eye, hook, etc.) to allow the handpieces to hang down from above the work area at the ideal height. This "cable / handpiece overhead suspension" permits significantly faster handpiece access / changeovers.*
- *By setting the temperature at approx. 50°C [122°F], you can use the slightly warmed Waxelectric blade to "shave" the wax crown edge onto the stump while the wax is warm.*

## 6. Cleaning / Maintenance



**Never rinse the unit off with water!**



**Do not use steam to clean the unit! Hot steam penetrating the unit can damage it.**

Use a soft, lint-free cloth to wipe the unit down from time-to-time.



**Never use cleansers containing solvents!**

Wipe the tips off after use; This will prevent wax from burning onto the tip and maintain the tip's optimal heat conducting properties.

### 6.1 Changing Tips



**Burn hazard!**  
**The modelling tips may be hot. Always allow the tips to cool before changing them.**

- Unscrew the tip (Figure 11).
- Make sure the O-ring is properly seated on the new insert (Figure 12).
- Insert the new tip making sure it is straight and hand-tighten it.  
Make sure the new tip IS NOT skewed or cross-threaded (Figure 1).



**Make sure the O-ring is properly seated (Figure 12), the O-ring provides a seal against the wax.**

Modelling tips which are not being used can be safely and handily stored in the tip holder (Figure 8).

### 6.2 Changing the cork sleeve

- Unscrew the tip (Figure 11).
- Pull the cork sleeve off towards the front (Figure 13).
- Install a new cork sleeve, making sure it is straight (Figure 14).
- Screw the tip back on (Figure 1).

### 6.3 Cleaning the Quiver and Tip Holder

The tip holder and quiver can be easily removed for cleaning.

- **Tip holder:**  
Press gently from the side, then flip upwards and pull off towards the rear (Figure 15 + 16).
- **Quiver:**  
Rotate the quiver downwards and towards the rear to remove it (Figure 17).

Remount tip holder and quiver in reverse order.

## 7. Spare Parts

For the order numbers of consumables and spare parts please refer to the spare parts list at the end of this manual.

## 8. Disposal

In order to protect the environment and to improve the reuse of raw materials (recycling), an agreement has been reached at the European level which requires manufacturers to take back recently produced electrical and electronic devices in order to introduce them into a regulated disposal or recycling system.

All devices identified by the following symbol are subject to this agreement:



These devices MAY NOT be disposed of as residential waste.

For more information regarding proper disposal or return options, please refer to the following Internet site:

[www.renfer.com](http://www.renfer.com)

## 9. Warranty

Provided the unit is properly used and with the exception of components subject to normal wear, Renfert **warrants** the all components of the *Waxlectric* for a period of **3 years**.

Warranty claims may only be made upon presentation of the original sales receipt from the authorized dealer.

Components subject to natural wear (e.g., all tips, handpieces, etc.) are excluded from this warranty.

The warranty is voided in case of improper use; failure to observe the operating, cleaning, maintenance, and connection instructions; in case of independent repairs or repairs by unauthorized personnel; if spare parts from other manufacturers are employed, or; in case of unusual influences or influences not in compliance with the utilization instructions.

Warranty service shall not extend the original warranty.

## 10. Technical Specifications

Max. power consumption: 5 W (*Waxlectric I*)  
10 W (*Waxlectric II*)

Min. operating temperature: 50°C [122°F]

Max. operating temperature: 200°C [392°F]

Supply voltage: 12 VDC

Transformer:

Input voltage: 100-240 VAC, 50/60 Hz

Output voltage: 12 VDC / 1A

## 11. Standard Delivery

- 1 Control unit with integrated holder for heating handle and tips
- 1 Handpiece (or 2 handpieces with the *Waxlectric II*)
- 1 Modelling insert, No. 2155-0102 (for *Waxlectric I*),  
or 2 inserts, No. 2155-0101 + 2155-0103 (for *Waxlectric II*)
- 1 Transformer
- 1 Operating instructions, with spare parts list

## 12. Delivery Versions

No. 2156-0000 *Waxlectric I*, 230 V

No. 2156-1000 *Waxlectric I*, 120 V

No. 2157-0000 *Waxlectric II*, 230 V

No. 2157-1000 *Waxlectric II*, 120 V

## 13. Accessories

No. 2151-1500 Kit of holders *Waxlectric*

No. 2155-0101 1 probe, small

No. 2155-0102 1 probe, medium

No. 2155-0103 1 probe, large

No. 2155-0104 1 blade, narrow

No. 2155-0105 1 blade, wide

No. 2155-0106 1 blade, chamfer

No. 2155-0107 1 Hollenback, horizontal

No. 2155-0108 1 Hollenback, vertical

No. 2155-0109 1 probe, mini, angled

No. 2155-0110 1 lance blade

No. 2155-0111 1 blade, beaver-tail

No. 2155-0112 1 large wax knife

2155  
-0101 -0102 -0103 -0104 -0105 -0106 -0107 -0108 -0109 -0110 -0111 -0112



## 14. Troubleshooting

Error	Possible cause	Corrective action
<b>Display does not go on, unit does not operate.</b>	<ul style="list-style-type: none"> <li>• Control unit not switched on.</li> <li>• Power supply interrupted.</li> <li>• Faulty control unit.</li> <li>• Faulty transformer.</li> <li>• Short circuit in the tip.</li> </ul>	<ul style="list-style-type: none"> <li>• Switch the control unit on at key A.</li> <li>• Check the power supply and reconnect, as required.</li> <li>• Have unit replaced by Service Department.</li> <li>• Replace with spare (refer to the spare parts list).</li> <li>• Clean the tip and handpiece (use compressed air).</li> <li>• Replace the tip.</li> <li>• Faulty heater handle --&gt; Replace with spare (refer to the spare parts list).</li> </ul>
<b>Unit operating, but no temperature at the tip.</b>	<ul style="list-style-type: none"> <li>• Tip not properly screwed in.</li> <li>• Tip / handpiece contact contaminated.</li> <li>• Faulty tip.</li> <li>• Handpiece cable not properly plugged into the control unit.</li> <li>• Plug on handpiece cable shows signs of corrosion.</li> </ul>	<ul style="list-style-type: none"> <li>• Hand tighten tip.</li> <li>• Clean the contact (use compressed air).</li> <li>• Replace the O-ring (refer to the spare parts list).</li> <li>• Replace with a new tip (refer to Sec. 13 / "Accessories").</li> <li>• Fully insert the handpiece cable into the socket until the cable locks in place.</li> <li>• Reinsert the plug, clean the contacts, if required.</li> </ul>
<b>Values are not saved.</b>	<ul style="list-style-type: none"> <li>• Memory chip faulty.</li> </ul>	<ul style="list-style-type: none"> <li>• Have the unit repaired.</li> </ul>
<b>Pressing the P key always displays the same temperature same temperature.</b>	<ul style="list-style-type: none"> <li>• The same temperature has been saved to each memory location.</li> </ul>	<ul style="list-style-type: none"> <li>• Assign different temperatures to each memory location (refer to Sec. 5.6).</li> </ul>



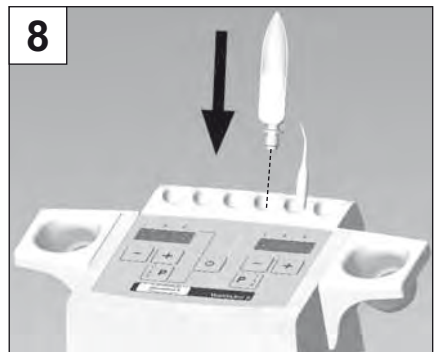
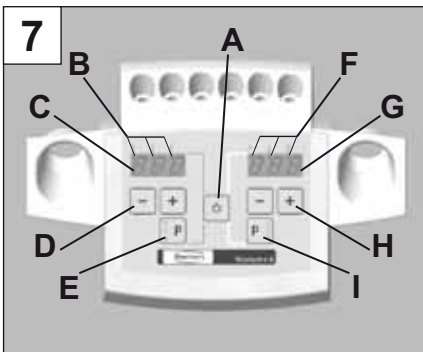
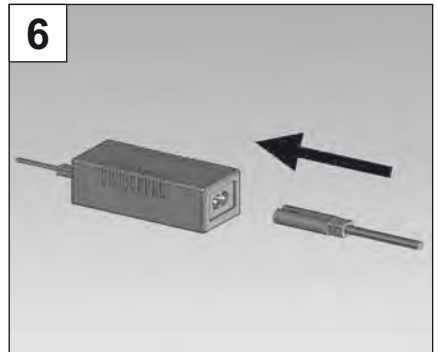
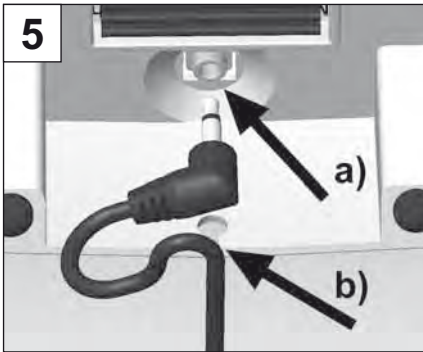
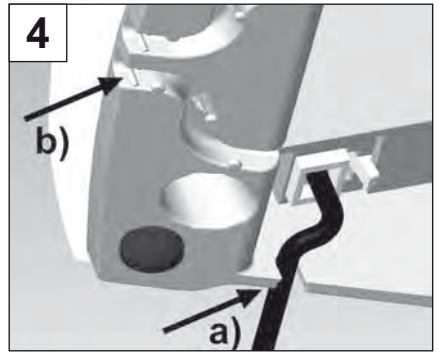
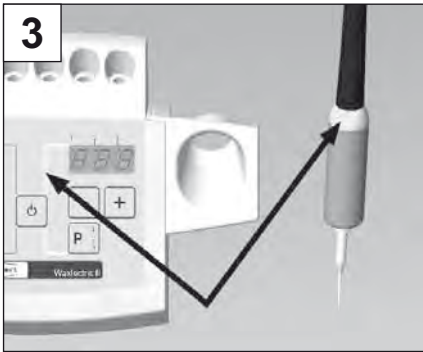
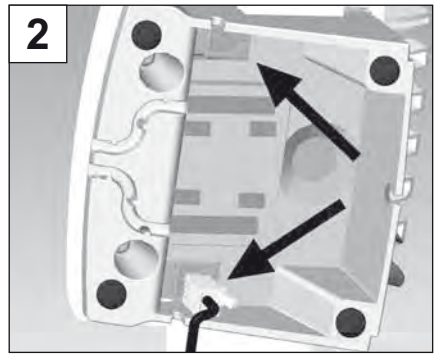
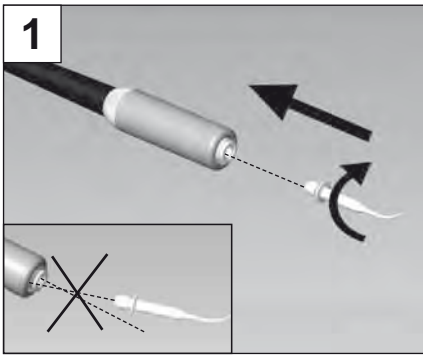

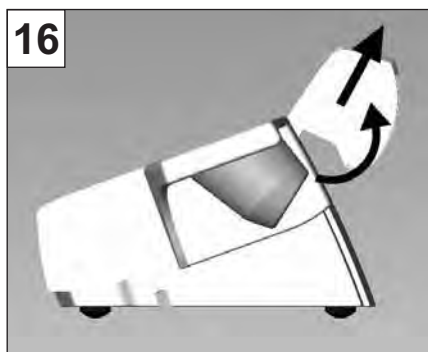
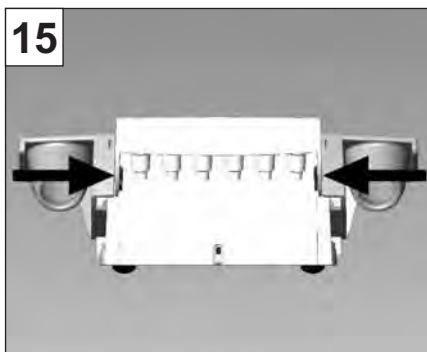
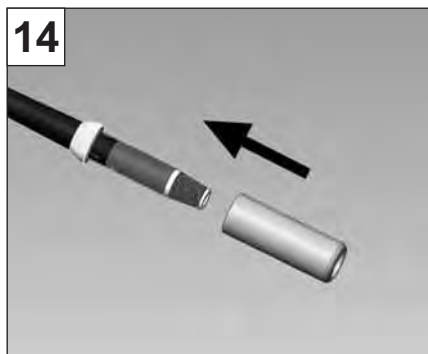
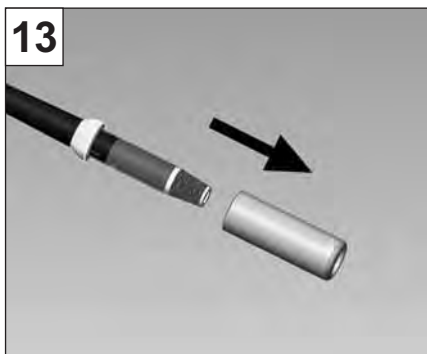
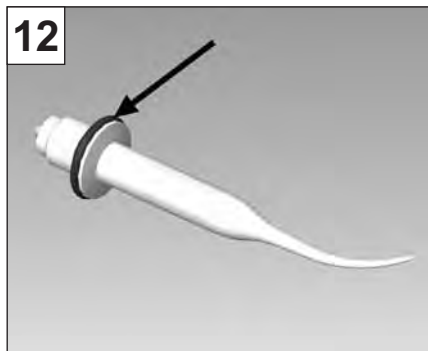
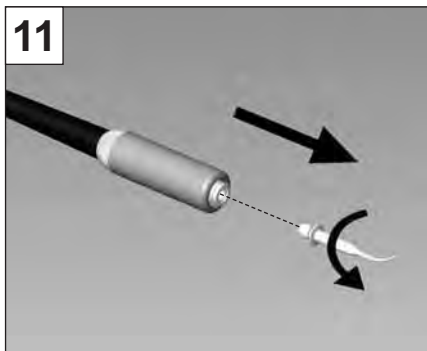
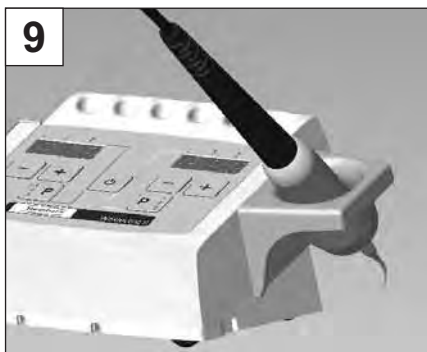

17



18

